

METRIC BITE TYPE FITTINGS

GE-SM - STRAIGHT MALE STUD COUPLING

Male Stud Thread METRIC;Cutting Face DIN 3852 Form 'B';(On Request Form 'A' also Available)

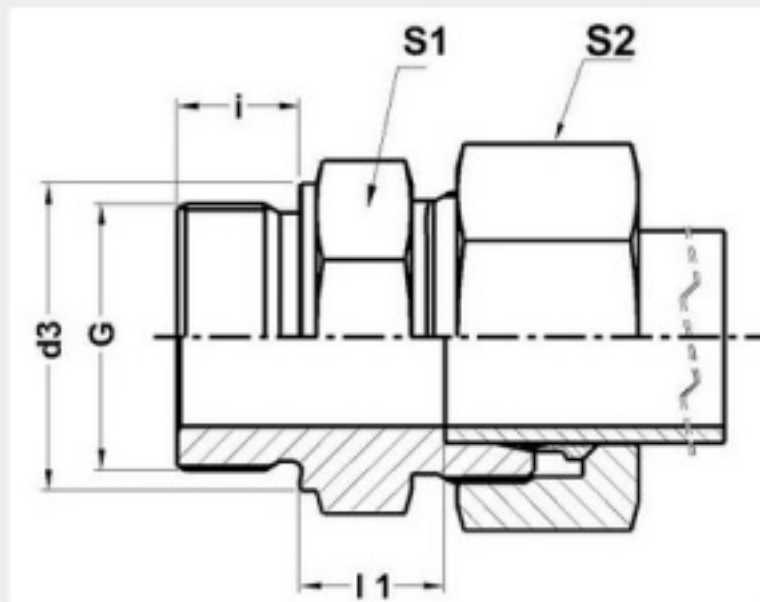

ORIENT ENGINEERING WORKS

Part No.	Series	Tube OD	l_1	i	S_2	S_1	d_3	G
GE 06 SM	Heavy-630 Bar	6	12	12	17	17	17	M12 X 1.5
GE 08 SM	Heavy-630 Bar	8	15	12	19	19	19	M14 X 1.5
GE 10 SM	Heavy-630 Bar	10	15	12	22	22	21	M16 X 1.5
GE 12 SM	Heavy-630 Bar	12	17	12	24	24	23	M18 X 1.5
GE 12 SM	Heavy-630 Bar	12	17.5	14	24	27	27	M22 X 1.5
GE 14 SM	Heavy-400 Bar	14	19	14	27	27	25	M20 X 1.5
GE 16 SM	Heavy-400 Bar	16	18	12	30	27	23	M18 X 1.5
GE 16 SM	Heavy-400 Bar	16	18.5	14	30	27	27	M22 X 1.5
GE 20 SM	Heavy-400 Bar	20	20.5	16	36	32	32	M27 X 2.0
GE 25 SM	Heavy-400 Bar	25	23	18	46	41	39	M33 X 2.0
GE 30 SM	Heavy-250 Bar	30	23.5	20	50	50	49	M42 X 2.0
GE 38 SM	Heavy-250 Bar	38	26	22	60	55	55	M48 X 2.0

DIMENSIONS GIVEN APPROX. FIG. WITH TIGHTENED NUT.

PART NO. GIVEN REFERES TO COMPLETE ASSEMBLY - STEEL PART